

ALCO

Solutions for a Cleaner Environment



CHEMICAL SANITIZING SINGLE RACK FRONT LOADING DISHWASHER

EST-FL

Low Temperature
Single Rack
Dishwasher



FEATURES

- 75% less floor space than traditional Dishmachines (compact space-saving design)
- Standard 20"X20" racks
- Requires only 5.06 sq ft of floor space
- Front loading door design provides optimal working height for easy loading and unloading of dishes
- 90 sec cycle (40 racks per hour)
- Energy Star water saving design uses only 1.09 gallons of water per cycle
- Standard 115v electrical circuit
- Powerful Stainless Steel pump with Upper and Lower Wash Arms
- Pumped fresh water rinse system
- Low-temp chemical sanitizing system which requires minimum 120 degree, ideal 140 degree water supply
- Top mounted controls with automatic 3-product dispensing system
- Large 16" dish clearance height
- Interchangeable components compatible with other CMA products
- Inside sump design
- ETL/UL/Energy Star Certified
- Includes 1 peg rack and 1 flat rack

CMA MODEL: EST-FL



Internal power drain saves space, has quiet activation and drains quickly.

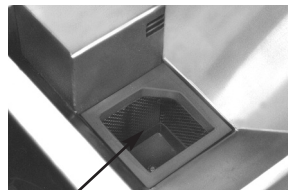

Self cleaning pump screen prevents service calls.

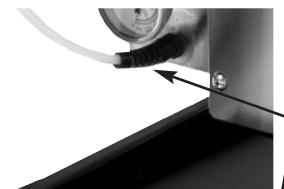

Sanitizing system sanitizer injector is located close to pump allowing sanitizing to take place immediately. Strategic location eliminates chlorine damage to the machine.



Built-in Poly Pro Scrap Accumulator with stainless steel tray and cover.

AVAILABLE OPTIONS

- Built-in Hot Water Assurance System provides hot water every cycle
- Low Chemical Alarm
- CMA Front Skirt
- Alternative Cycle Times
- Alternative Electrical Available

CMA
MIZER
Registered Trademark





EST-FL (FRONT LOADER)

Chemical Sanitizing Single Rack Dishmachine

WARNINGS:

- Plumbing connections must be made by a qualified service company who will comply with all available Federal, State, and Local Health, Plumbing and Safety codes.
- CMA recommends utilizing a water softening system to maintain water hardness measurements of 3.5 gpg (grains per gallon) or less. This will assure maximum results and optimum operation of the dishmachine.

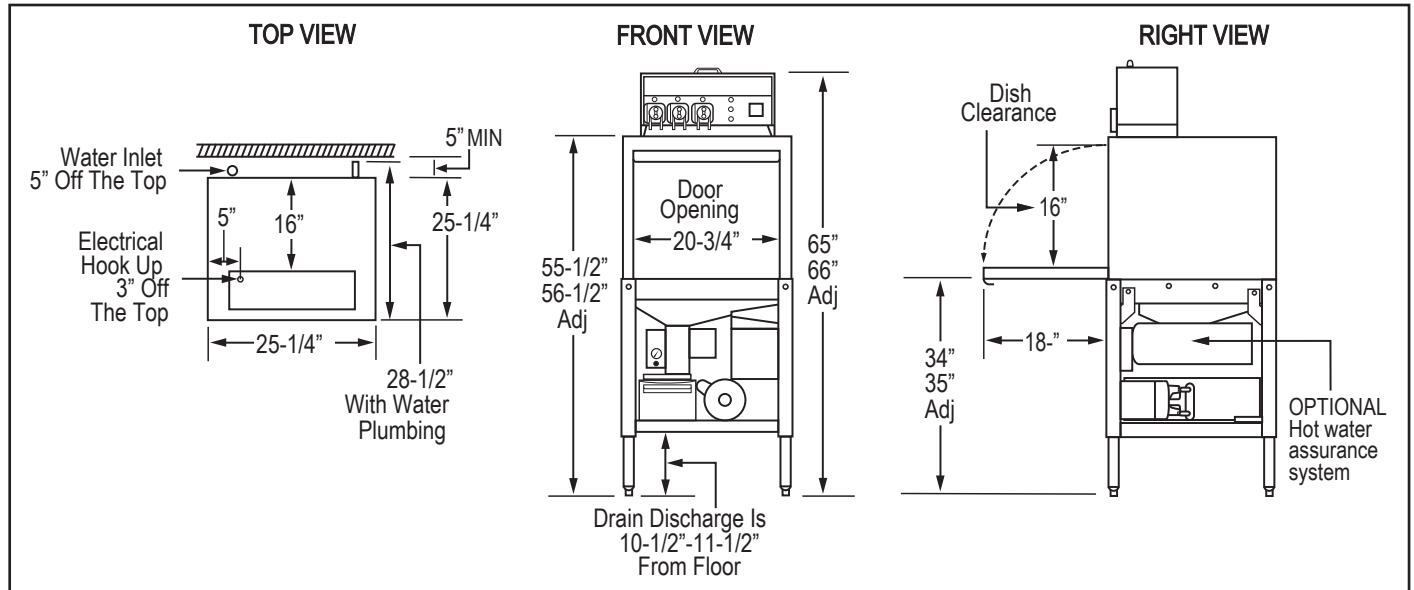

Specifications:

MODEL EST-FL	USA	METRIC		USA	METRIC
WATER CONSUMPTION			FRAME DIMENSIONS		
PER RACK	1.09 GAL.	(4.12L)	DEPTH	25-1/4"	(64.1cm)
PER HOUR	43.6 GPH	(165 L)	WIDTH	25-1/4"	(64.1cm)
WATER INLET	1/2"	(1.27cm)	HEIGHT	55-1/2"-56-1/2"	(141.2cm-143.5cm)
DRAIN	2"	(5.1cm)	MAXIMUM CLEARANCE HEIGHT FOR DISHES	16"	(40.6cm)
OPERATING CYCLE			STANDARD DISHRACK	1	1
WASH TIME - SEC.	53	53	DIMENSIONS	20"X20"	(50.8 x 50.8cm)
RINSE TIME - SEC.	30	30	WASH PUMP MOTOR HP	1	1
DWELL	7	7	ELECTRICAL RATING	VOLTS	AMPS
TOTAL CYCLE	90	90	WITH HOT WATER	115	16
OPERATING CAPACITY				115	16
RACKS PER HOUR	40	40	APPROXIMATE SHIPPING WEIGHT	243# (With HTR)	(110 kg)
WASH TANK CAPACITY	1.09 GAL.	(4.12 L)		243# (With No HTR)	(110 kg)
PUMP CAPACITY	52 GPM	(197 LPM)	SHIPPING DIMENSIONS	PALLET & BOX @ 41" X 41" X 66" (With HTR)	
OPERATING TEMPERATURE				PALLET & BOX @ 41" X 41" X 66" (No HTR)	
REQUIRED	120°F	(49°C)			
RECOMMENDED	140°F	(60°C)			

Summary Specifications: Model EST Front Loader

The Energy Miser model EST FRONT LOADER low temperature, chemical sanitizing commercial dishwasher meets UL Electrical and ETL Sanitation (NSF Standard 3) standards. Model EST FRONT LOADER is constructed entirely of stainless steel. Each unit automatically washes, rinses and sanitizes food service utensils in standard 20" x 20" racks. Unit comes with upper and lower stainless steel wash arms.

Advisory: CMA does NOT endorse "Tankless On-Demand" water heaters for use on CMA Dishmachine products. CMA DOES endorse, and highly recommends, the standard "tank" style water heaters, sized properly to handle each particular facility with their water heating requirements.



www.alco-chem.com

NORTH: 45 N Summit Street, Akron, OH 44308 | Hours: M-F, 8:00-4:30 | PH: 330.253.3535 | 1.800.589.2526

SOUTH: 1303 Park Avenue SW, Canton, OH 44706 | Hours: M-F, 8:00-4:30 | PH: 330.833.8551 | 1.800.437.5248